

LITHIONICS BATTERY®

LITHIUM-ION IRON PHOSPHATE BATTERY SYSTEMS



MODEL NUMBER:
GTX12V315A-E2107-CS200

Designed with Bluetooth® Wireless Monitoring,
Internal Heater Kit, Aluminum Alloy Enclosure



INTERNAL BMS
VERSION



Wireless Battery Monitoring via
Lithionics Battery® Monitor App



Application Note: Compatible with a Maximum Inverter Size of 3000 Watts. Do Not Connect to Larger Inverters or to Parallel-Connected Inverters.

Item	Description
Model	GTX12V315A-E2107-CS200
Nominal Voltage	12.8V
Nominal Capacity	315Ah
Nominal Watt Hours	4032Wh
Internal Resistance	<3mΩ
Charge	
Charging temperature range	32F/0C to 131F/55C
Charge voltage	14.4V
Recommended float charge voltage(for standby use)	13.4-13.6V
Recommended charge current*	150A
Maximum charge current*	200A
Discharge	
Discharging temperature range	-4F/-20C to 131F/55C
Operating Voltage Range	10.4-13.4V
Recommended discharge current*	150A
Maximum discharge current*	230A
Pulse discharge current (1 second)	1200A
Discharge cut-off voltage	NeverDie® Power Reserve @ 12.0V Low-Voltage Cut-Off @10.4V
Mechanical	
Dimensions	Length 20.3" Width 6.6" Height 10.7"
Mounting Orientation	Upright position only (terminals up)
Weight	Approx. 68lbs (30.8kg)
Terminal Bolt Size	M8-1.25x14mm
Storage	
Storage Temperature & Humidity Range	< 1 Month -4~95°F (-20~35°C), 45~75%RH < 3 Months 14~86°F (-10~30°C), 45~75%RH Recommended storage 59~95°F (15~35°C), 45%RH~75%RH
Long Term Storage	If the battery needs to be stored for > 3 months the voltage should be 13.2V (50%SOC), and stored at the recommended storage specifications shown above. Additionally, the battery needs at least one charge & discharge cycle every six months.
Self-discharge rate	Residual capacity ≤3% per month; ≤15% per year Reversible capacity ≤1.5%per month; ≤8% per year

* Maximum charging and discharging rates apply depending upon the ambient temperature and duty cycle of the system. UL1973 tests of maximum charge and discharge current were performed at 25°C/77°F



30% Smaller than 3 x 100Ah Group31
Batteries, with Extra 15Ah to Spare

INTERNAL NEVERDIE® BMS FEATURES

- NeverDie® Power Reserve (Spare Fuel) for Hotel Loads and Engine Cranking
- Over-Charge, Over-Discharge and Short-Circuit Protection (LVC, HVC, SCC)
- Low/High Temperature Charge/Discharge Protection
- Internal Heating Kit: Permits Charging as low as -20C/-4F
- Pushbutton On/Off switch for Safety and Storage
- Battery Gauge and Status Codes for Health Monitoring
- Bluetooth wireless telemetry with Lithionics Battery iOS and Android app
- CANbus telemetry in the RVIA RV-C format (M12)
- An alternator Field Control Circuit (FCC) (AMPSEAL8)
- Remote LED illuminated On/Off Power switch (AMPSEAL8)

ENERGY

315 AMP HOURS

PULSE AMPS: 1200 (1 SEC)

4032 WATT-HOURS

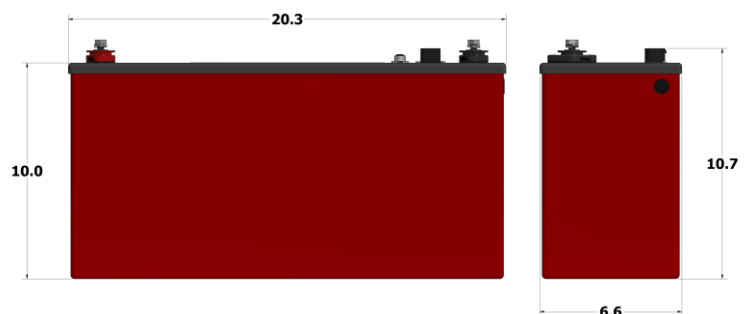

PART NUMBER:
75-H1FBR-CS Ampseal 8 Harness Kit

EXTERNAL
ACCESSORIES

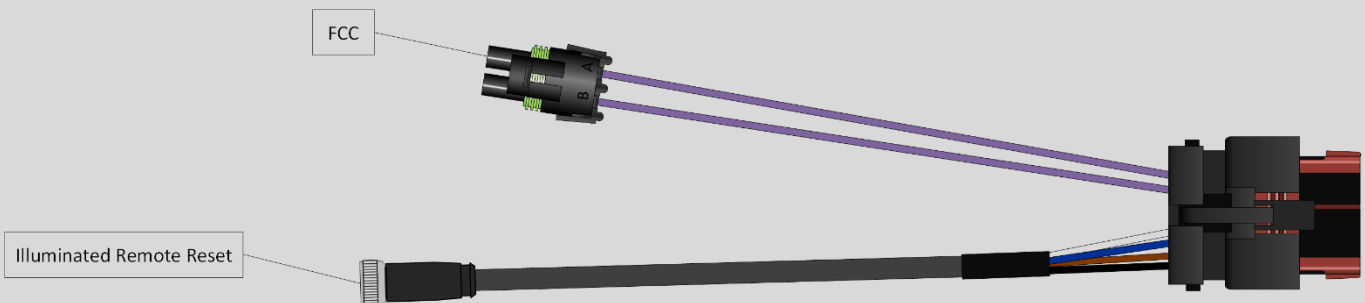

Feature	Description
FCC	Alternator Field Control Circuit
Remote Reset Switch	Illuminated Remote Momentary Power Switch

ABOUT AMPSEAL 8

The mating Ampseal 8 connector kit is designed for use with any battery equipped with the NeverDie® Compact Series 200 Internal Battery Management System (BMS). The 8 pin Ampseal connector is located on the top of the battery and is used to access the BMS's ported features. This allows implementation of the combination of BMS functions listed above. Mating cable extensions are optional and available separately per the part numbers listed below.

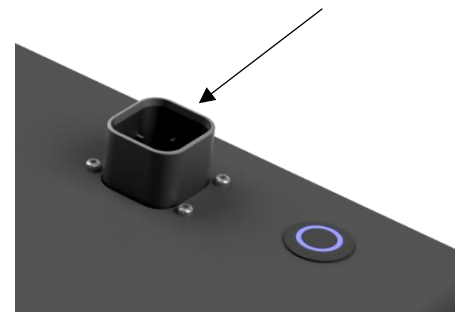

Optional Mating Extensions:		
Part Number	Model	Description
75-149-180	FCC Extension	Dual Weatherpack Connector to Bare Wires, 15ft Length
75-224-196	Illuminated Remote Reset	M8 Connector to Illuminated Remote Switch, 16ft Length

Note: Contact factory regarding mating connections for CANBus feature.